

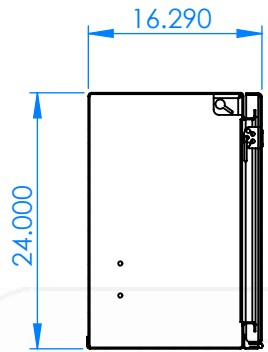

SHORT BOX

X-SIDES
HIGH SIDE TRUCK BOXES





SECTION A-A
SCALE 1 : 18

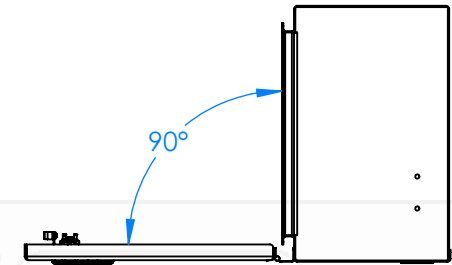
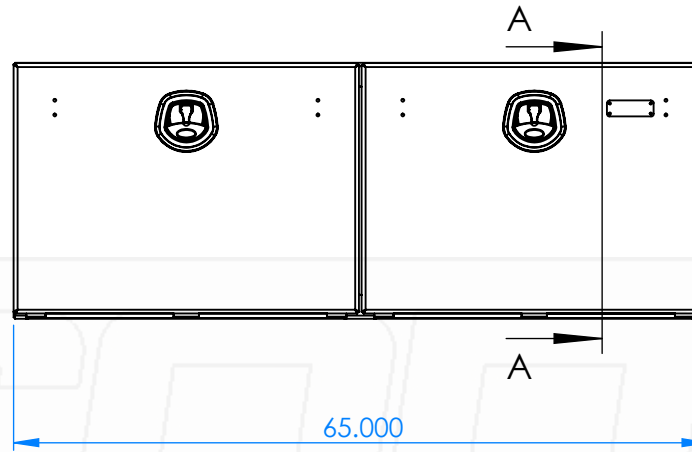

FOLD DOWN DOORS W/ CHAINS

CHECKER DOORS

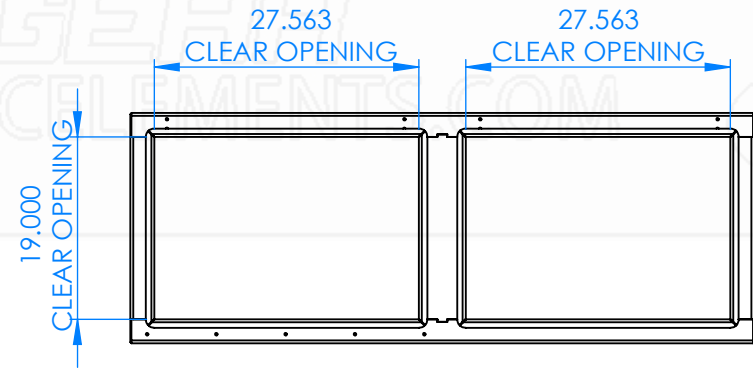
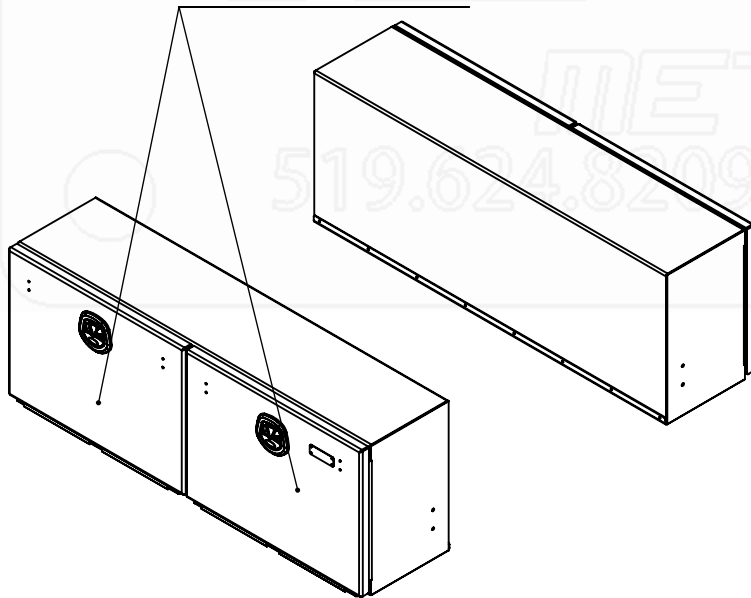

Part No.:

3065

MATERIAL: 5052 (Alum)

Approx. Weight: 204.00 lbs

Surf. Area: 206.81 sq. ft.

THICKNESS: 0.125

ICONIC ELEMENTS (ICONIC METALGEAR) TITLE:

PROPRIETARY AND CONFIDENTIAL
NO PART OF THIS DOCUMENT MAY BE REPRODUCED, STORED IN A RETRIEVAL SYSTEM, OR TRANSMITTED IN ANY FORM, WITHOUT THE WRITTEN PERMISSION OF Iconic Elements Inc. (ICONIC METALGEAR)

FINISH: Smooth

X-Side Box - CH (Short)

DWG. NO.: 4041-C-00-A

REV: SHEET:

A 1 OF 1